

# Manual Tube Puller

For 3/8" – 1" Tube OD - Model #904500



Tube & Pipe Cleaners ○ Tube Testers ○ Tube Plugs ○ Tube Removal ○ Tube Installation



## Operating and Maintenance Instructions

[www.elliott-tool.com](http://www.elliott-tool.com)





# TABLE OF CONTENTS

Introduction ..... 4

Safety Guidelines ..... 4

Unpacking ..... 5

Operation Instructions..... 5

Quick Reference Diagrams..... 6

Spear Selection Chart ..... 7

Warranty ..... 8

# INTRODUCTION

Thank you for purchasing this Elliott product. The design and manufacture of this tool represents the highest standard of quality, value and durability. Elliott tools have proven themselves in thousands of hours of trouble free field operation.

If this is your first Elliott purchase, welcome to our company; our products are our ambassadors. If this is a repeat purchase, you can rest assured that the same value you have received in the past will continue with all of your purchases, now and in the future.

The Elliott Manual Tube Puller is a portable tube extractor for removing or extracting tubes from heat exchangers, condensers, chillers and boilers.

We at Elliott would like you to be completely satisfied with this tool and therefore recommend that this instruction manual be thoroughly read prior to use.

This tool has been designed and manufactured to the highest standards, using the latest in materials and technology. If the guidelines and maintenance schedules in this manual are followed, this tool will provide many years of trouble free operation.

Elliott Tool Technologies Ltd shall not be liable for errors contained herein or for incidental or consequential damage in connection with the furnishing, performance, or use of this material.

## SAFETY

Every effort has been made to ensure the operation of the tube extractor is safe, although it is impossible to remove all possibilities of accidents.

It is very important that **all operators** of this machine are fully aware of the following safety considerations.

1. If you are unfamiliar with this Manual Tube Puller, read this Operation Manual thoroughly before use.
2. Always wear safety glasses, protective gloves, safety shoes and protective clothing.
3. Do not allow other people in the work area unless they are wearing suitable protective clothing and equipment.
4. Never use the Elliott Manual Tube Puller, or any other power tool when under the influence of medication, drugs or alcohol that decrease concentration and impair operator control.

# UNPACKING

The Elliott Manual Tube Puller is shipped in a carton with some accessories. On arrival, check for external damage to the box. If damage is found, notify the carrier and the supplier so insurance inspectors can examine the box before it is unpacked. When opened, check the contents against the packing and parts list. Report any damage or shortage to Elliott.

NOTE: You will need an Elliott “E” Series Hex Spear and Nose Piece for the tube size to be extracted (see pages 6 & 7).

# OPERATION

The Manual Tube Puller will extract tubes with outside diameters ranging from 5/8” to 1”. Pulling spears are sized for the tube ID. Twenty-five standard spear sizes are available. The spear selection chart for this tube puller is listed on page 7.

1. Determine the OD and ID of the tubes to be extracted.
2. Select the proper spear and nose piece to be used for the tube to be pulled.
3. Screw the spear into the thrust collar assembly.
4. Place the nose piece over the front end of the thrust collar assembly.
5. Thread the self-feeding spear into the tube I.D. in clockwise rotation. This can be done by hand or with a pneumatic impact wrench.
6. Position the drive socket over the rear end of the thrust collar assembly.
7. Connect either a manual or impact wrench to the 7/8” hex.
8. Extract the tube by rotating the wrench in clockwise rotation.
9. Remove the spear from the extracted tube or tube stub.

# QUICK REFERENCE DIAGRAMS

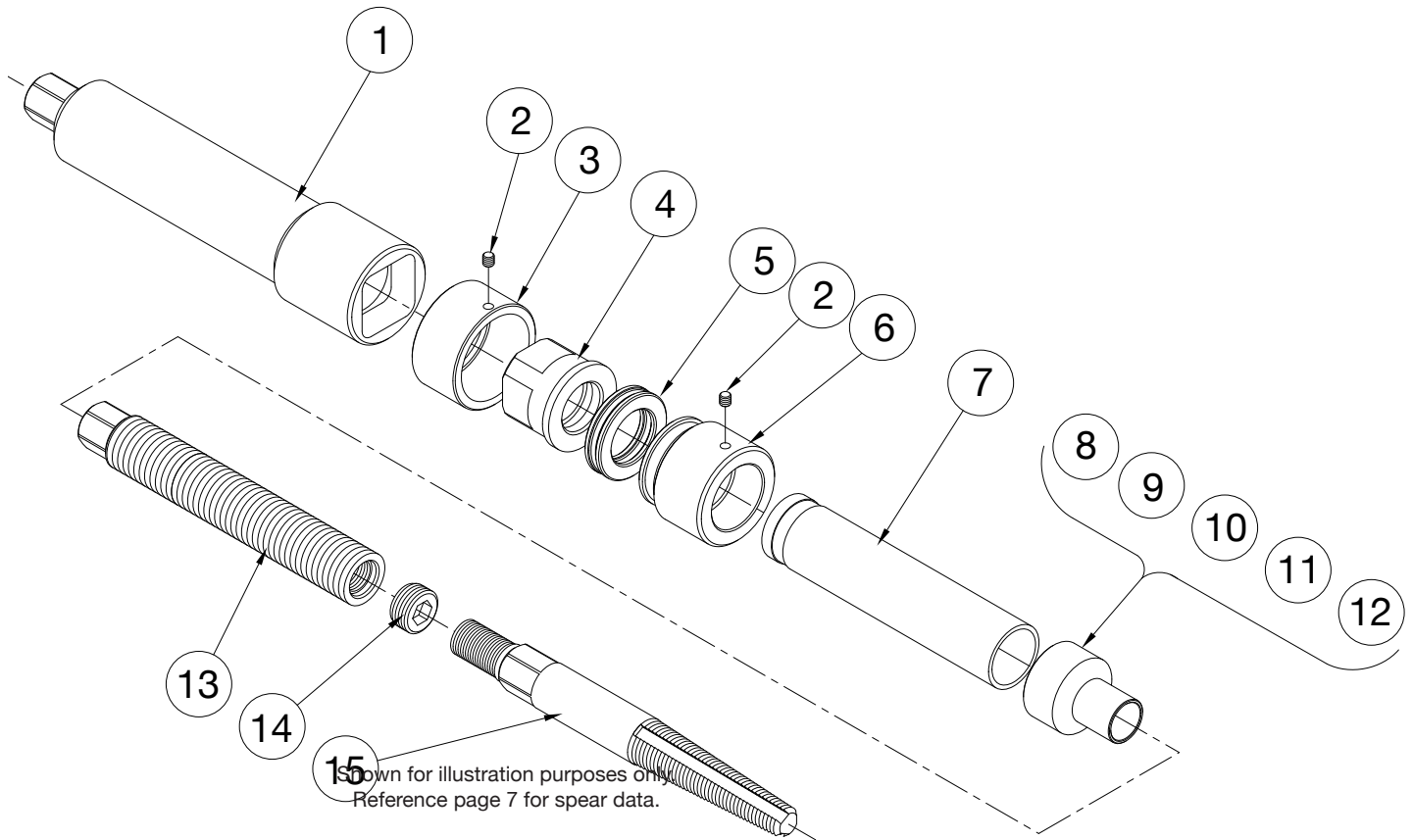

Shown for illustration purposes only.  
Reference page 7 for spear data.

**Hex Drive Size: 7/8" \*\***  
\*\* 5/8" across flats on 3/8" spear.

Item No.	Description	Qty	Part Number
1	Drive	1	904512
2	Set Screw	3	128L
3	Housing	1	904509
4	Adjustment Collar	1	904511
5	Bearing	1	PC80-51106
6	Thrust Collar	1	904507
7	Thrust Extension	1	904505
8	Nose Piece (3/8" Tube) *	1	904502-04
9	Nose Piece (1/2" Tube) *	1	904502-05
10	Nose Piece (5/8" Tube) *	1	904502-01
11	Nose Piece (3/4" Tube) *	1	904502-02
12	Nose Piece (1" Tube) *	1	904502-03
13	Body	1	904506
14	Jam Screw	1	173HA
15	Spear (Not Included in Assembly) <i>(Shown for Illustration Purposes Only)</i>	1	See Page 7

\*Optional. Must be ordered separately.

# SPEAR SELECTION CHART

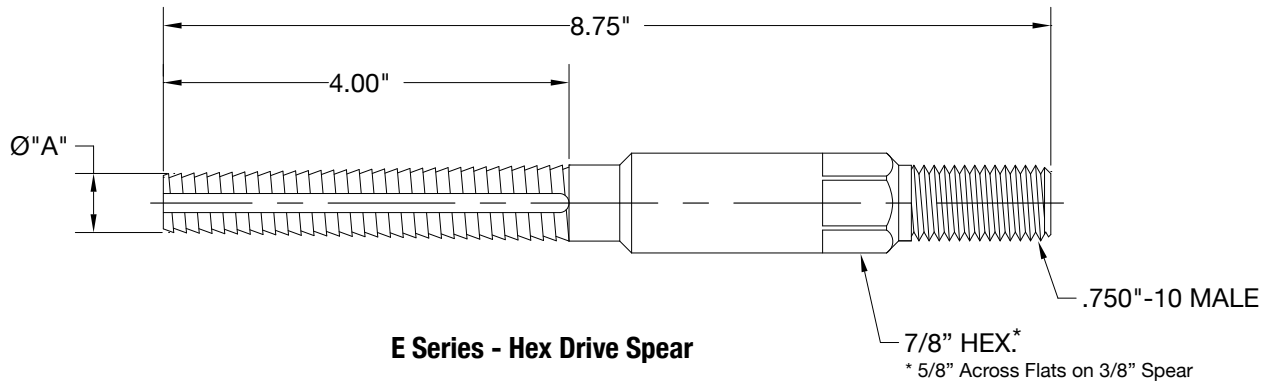

Size Range	Part No.	"A" Ø
3/8" x 20-22 Ga.	E375-20	.295"
1/2" x 20-22 Ga.	E500-20	.427"
5/8" x 12-13 Ga.	E625-12	.402"
5/8" x 14-15 Ga.	E625-14	.454"
5/8" x 16-17 Ga.	E625-16	.489"
5/8" x 18-19 Ga.	E625-18	.521"
5/8" x 20-22 Ga.	E625-20	.545"
3/4" x 8-9 Ga.	E750-8	.410"
3/4" x 10-11 Ga.	E750-10	.470"
3/4" x 12-13 Ga.	E750-12	.520"
3/4" x 14-15 Ga.	E750-14	.579"
3/4" x 16-17 Ga.	E750-16	.614"
3/4" x 18-19 Ga.	E750-18	.646"
3/4" x 20-22 Ga.	E750-20	.670"
7/8" x 14-15 Ga.	E875-14	.699"
7/8" x 16-17 Ga.	E875-16	.740"
7/8" x 18-19 Ga.	E875-18	.760"
7/8" x 20-22 Ga.	E875-20	.800"
1" x 8-9 Ga.	E1000-8	.660"
1" x 10-11 Ga.	E1000-10	.720"
1" x 12-13 Ga.	E1000-12	.777"
1" x 14-15 Ga.	E1000-14	.829"
1" x 16-17 Ga.	E1000-16	.864"
1" x 18-19 Ga.	E1000-18	.896"
1" x 20-22 Ga.	E1000-20	.920"

# **WARRANTY**

Should any part, of Seller's own manufacture, prove to have been defective in material or workmanship when shipped (as determined by Seller), Seller warrants that it will, at its sole option, repair or replace said part f.o.b., point of manufacture, provided that Buyer notifies, in writing, of such defect within twelve (12) months from date of shipment from the manufacturing plant.

On request of Seller, the part claimed to be defective will be returned, transportation, insurance, taxes and duties prepaid, to the factory where made, for inspection. Any item, which has been purchased by Seller, is warranted only to the extent of the original manufacturer's warranty to Seller. Seller shall not be liable for any damages or delays caused by defective material or workmanship.

No allowance will be made for repairs or alterations made by others without Seller's written consent or approval. If repairs or alterations are attempted without Seller's consent, Seller's warranty is void.

THE WARRANTIES PROVIDED IN THE OBLIGATIONS AND LIABILITIES OF SELLER HEREUNDER, AND THE RIGHTS AND REMEDIES OF BUYER HEREUNDER ARE EXCLUSIVE AND IN SUBSTITUTION FOR, AND BUYER HEREBY WAIVES ALL OTHER WARRANTIES, GUARANTEES, OBLIGATIONS, CLAIMS FOR LIABILITIES, RIGHTS AND REMEDIES, EXPRESS OR IMPLIED, ARISING BY LAW OR OTHERWISE, INCLUDING BUT NOT LIMITED TO THE IMPLIED WARRANTY FOR MERCHANTABILITY AND FITNESS FOR PURPOSE.

Seller's total liability is limited to the lower of the cost of repair or replacement.



**This Page Is Intentionally Left Blank**

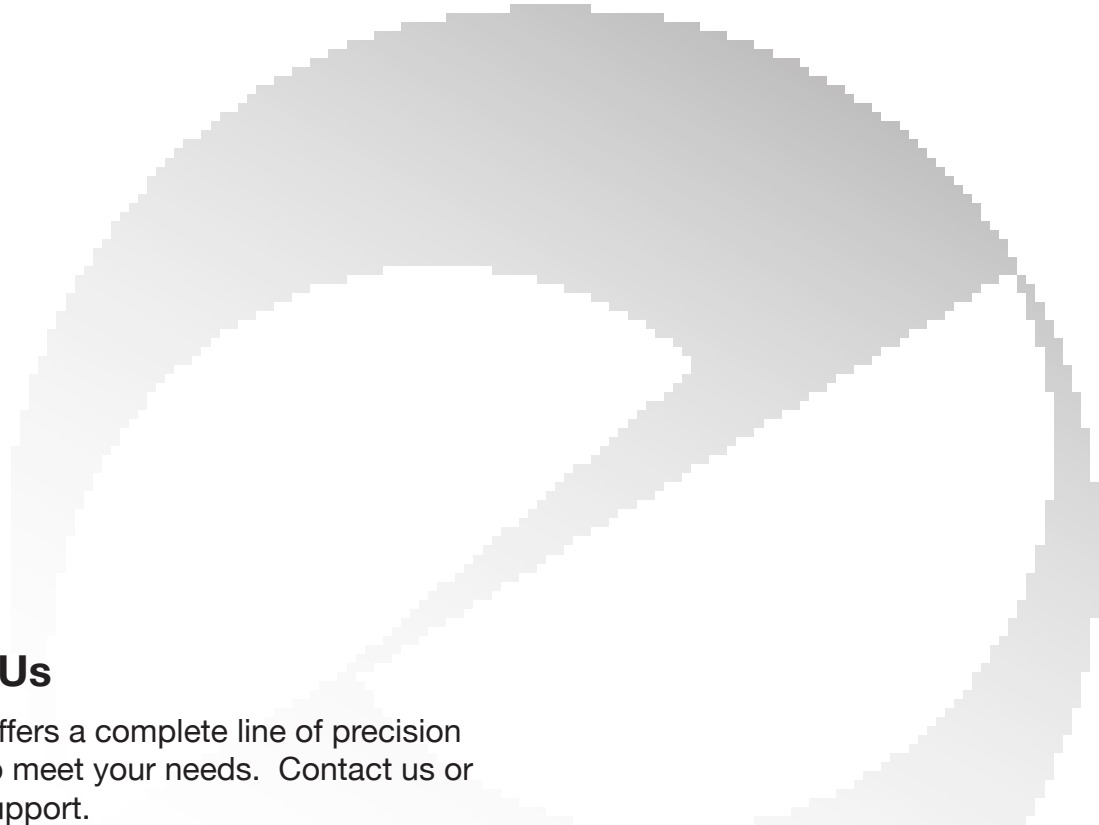

## Contact Us

Elliott Tool offers a complete line of precision tube tools to meet your needs. Contact us or your local support.

Elliott Tool Technologies, Ltd.  
1760 Tuttle Avenue  
Dayton, Ohio 45403-3428  
Phone: +1 937 253 6133 • +1 800 332 0447  
Fax: +1 937 253 9189  
[www.elliott-tool.com](http://www.elliott-tool.com)

### Locally Supported By:

[www.elliott-tool.com/support](http://www.elliott-tool.com/support)